



DISSECT THE HABIT. LEARN HOW TO QUIT IN 60 MINUTES!

*The Most Comprehensive
Smoking Cessation Program in the World*

14AndOut

CUT THE HABIT AND NEVER GO BACK!



Includes 60 Minute Downloadable Video from the Author/Teacher, Hands-on Activities Guide, 20 Question Pre-Test with Answers, and the Nutritional Guide.

- 1. Learn the BIG SECRET of WHY cigarettes are *so addictive*. Find out how MARLBORO AND KOOL hooked an entire nation of smokers in just a few years , nearly putting every other cigarette manufacturer out of business.**
- 2. Find out the 5 UNLISTED LETHAL INGREDIENTS, and how they keep you sick and tired.**
- 3. Understand why *the patch, pills, gum* rarely keep smokers away from cigs for long.**
- 4. Remove the chemicals from your life, and replace them with vitamins, nutrients, and daily confidence.**

Congratulations on your purchase! Let's get started:

Each page of this course is specifically designed with a **pattern of learning** and the **answers** to the tests are provided at the end. There are two sections, **Quitting Cigarettes** and **Nutrition & Mindset**. This course will *wean you off nicotine and all the other chemicals* in 14 days or less. Some smokers quit immediately upon finishing the 60 minute course! Included in this course are the following:

Photos, Charts and Illustrations - To help translate the *course's main ideas*.

Face the Facts – Know exactly what you're dealing with *instead of the lies* that keep you hooked. There are household chemicals in cigarettes that are depleting your system and keeping you from quitting. Learn how to replenish your system so you never go back.

What You'll Need – 5 common, *cheap household products* for **hands-on** concepts: Small samples of ammonia, bleach, pesticide, fiberglass insulation, and toothpaste. Also gather one cigarette (any brand), scissors, paper towel, and magnifying lens (optional).

Let's Find Out – Why are cigarettes so addicting? **Each page explains** exactly how cigarettes are designed to deplete your system's nutrients and keep you addicted.

What To Do – *First, print the guide, and watch the introduction of the 60 minute video! Then, read the introduction in the guide and take the pretest. After that, follow along w/video instruction during the hands-on activities.* Take the **shoppers guide** and go to the store. That's it! In the privacy of your own home, in 60 minutes, you will have the **knowledge and the tools** you need to quit and quit for good!

Nutritional Plan - - **This plan is included FOR FREE so you never go back to smoking.** How will you replace the nutrients that cigarettes have robbed from your system? What vitamins and supplements will kill the cravings of nicotine? How can vitamins change your mindset and provide for your confidence and relaxation? Just *how depleted is your system* right now? **This course offers you the best insight ever** into replacing the habit with food, vitamins and supplements that revitalize you. I have consulted with the best nutritionists in the world to bring you vital information you need to kill the urge to smoke.

Glossary – **Key terms are defined and explained as they relate to quitting smoking.**

Additional Resources – Where to find **more professional info** on the major topics.

TAKE THE 20 QUESTION PRE-TEST NOW!

Get out a clean sheet of paper and number vertically from **1 to 20 on the front** and then **1 to 10 on the back** (or you can print this and write on the back). At the top of your blank page, title the first test **Quitting Cigarettes**, and the second test **Nutrition**.

First, *simply guess* at the answers to the questions. The Cigarette Killer himself will then guide you through the questions and answers on the video using the hands-on activities and anecdotes to make sure you understand each step. Simply follow along and participate in the hands-on activities. You can't go wrong!

Quitting Cigarettes ...



Beginning in the early 1960's, when low tar cigarettes became popular, they had *less taste and less kick*. Cigarette manufacturers Marlboro discovered that adding Ammonia to the process and cooking it together with the tobacco made the **Nicotine up to 35 times stronger** (as a vapor) and gave the cigarettes that “roasty, toasty flavor.” Then all the other companies jumped on the money making band wagon. And now, thanks to the *lack of any regulation* of cigarettes and their ingredients, smoking a pack a day is equivalent to **smoking 700 cigarettes** in 1960. **If you wonder why it's hard to quit**, this is a major part of it. Let me show you in 60 minutes how to wean yourself off this chemical compound scam that's stealing your money and your health!

LET'S SEE HOW MUCH YOU KNOW ABOUT YOUR HABIT ...

KNOW THESE 20 QUESTIONS AND YOU CAN ESCAPE YOUR HABIT!

WRITE DOWN YOUR BEST GUESSES TO THE FOLLOWING:

1. Can you name **5 ingredients** in a cigarette?
2. Why are cigarettes **white**?
3. Why are cigarettes **so addicting**?
4. How do the **tobacco leaves contain poison**?
5. Why does it take **up to 15 years** for a cigarette filter to disintegrate?
6. How come cigarettes **burn so hot, so evenly, and never go out** in heavy wind?
7. What effect do **all of the chemicals** have on your body?
8. Why do the **pills, the patch, and nicotine gum fail** so many?
9. What government agencies **regulate the potency** of nicotine?
10. **Besides nicotine**, what is it about cigarettes that you're addicted to?
11. Is your **breathing pattern better when smoking**?
12. Do you have a **hand to mouth** habit?
13. Is smoking a form of **meditation**?
14. Why do most smokers enjoy a cigarette **after meals**?
15. Is there any such thing as **organic tobacco**?
16. What is the **art of breathing**?
17. Why do people often **put on weight after** they quit?
18. How can you learn to **hate cigarettes** if you like them now?
19. How will you **deal with the urge and with stress**?
20. What's the main reason the **pills don't work, but makes things worse**?

Part I. Bleach



Face the Facts – Bleach is in tons of common household products and food. ***Bleach is found in white foods like rice, flour, bread, pasta, and sugar! Bleach is found in coffee filters, toothpaste, and tooth whiteners that people sleep with in their mouths and swallow during the night.*** But none of these are *smoked and inhaled*, being mixed with other chemicals like *ammonia and pesticide*, **causing lethal consequences faster and more severe** than any other form.



Above is a photo of a cigarette manufacturing machine. Cigarettes are ***efficient nicotine delivery devices*** intended to keep you hooked, make you sick, and in need of expensive chemotherapy drugs. Even after just a few years of smoking, the premium brands are especially dangerous. Should you be racing towards disease or good health?

Let's Find Out – Side effects of consuming bleach include; cancer of the mouth, throat, larynx, esophagus, stomach, liver, kidneys, bladder and intestines. Bleach is a known toxin, even when simply inhaled. **Coupled with the nicotine the problems are compounded** and occur more frequently in humans. Check the diagram below for symptoms and conditions you have that *you may be blaming something else for*:

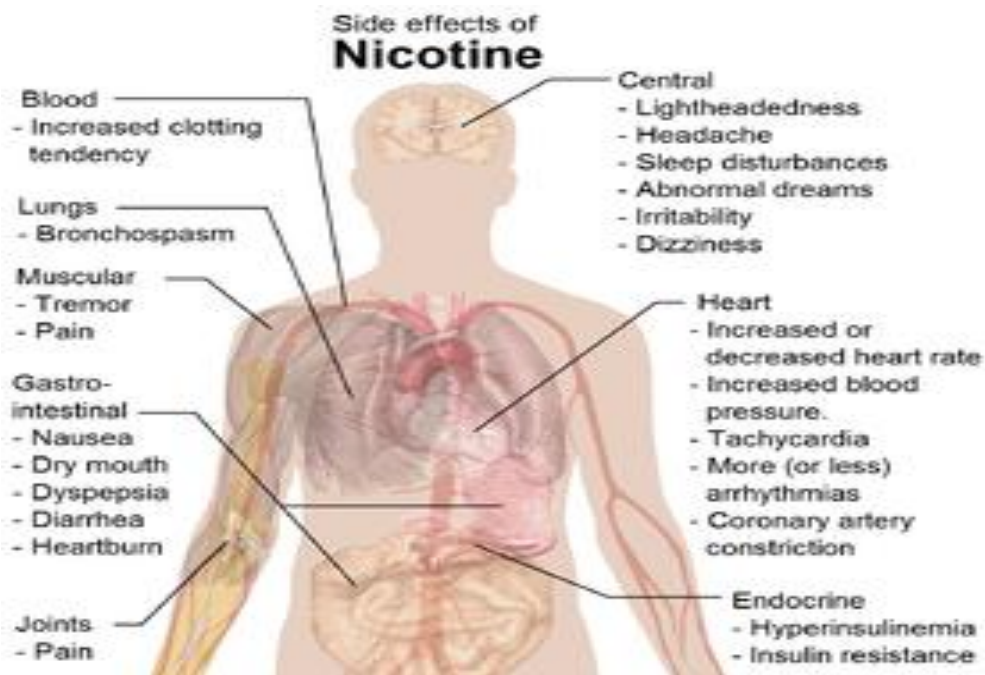

What You'll Need – One small container/sample of **common household bleach**.

What To Do – Open the container of bleach carefully now. **Slowly** bring your nose closer and closer to the top of the container until you catch a **small sniff** and smell the fumes. Even if you know what bleach smells like, *it is important to remind yourself now*.

Household Cleaning Chemicals and Products – Many consumers buy “white” foods and products because they look clean. Foods like rice and pasta are naturally brown and don't look as appealing to some for consumption. Brown cigarettes have the same stigma, resembling cigars. Being that cigarettes are obviously bad for you and not regulated, why wouldn't manufacturers bleach the paper. *They don't care about you or your life*, and the end result is a compound of poisons that bring you down and lead you to lighting up again.

Nutrients your body needs – Your liver, your kidneys, and your pancreas do their best to filter out chemicals. You cannot live without these organs. Right now, they are living in a state of shock. There are kidney cleansers available inexpensively now, and cleansers for all of your other organs, including intestines, bladder and prostate. *You do not want to ever deal with chemotherapy*, so pay close attention to the nutrients and nutritional advice is the next section regarding what to use for your body.

Part II. Ammonia



Face the Facts – The U.S. Government, including the FDA and the CDC, allows ALL cigarette manufacturers to use Ammonia in order to give nicotine over **35 times more addictive potential than normal**, which **does not register** on nicotine level testing. *Freebasing* is a chemical process where the tobacco is cooked together with Ammonia. Similar to the chemical process of freebasing cocaine, the end result is an *extreme, enhanced effect* of the nicotine potency. Ammonia is not listed as an ingredient on cigarette boxes or cartons.

Mouth, throat and lung cancer are the *most preventable cancers* in the world. All cigarette ingredients and manufacture should be monitored and strictly regulated by the Food and Drug Administration, and the CDC, the Center for Disease Control. The problem is that the tobacco companies earn billions and billions of dollars every year in part **because of the lack of these regulations**, but it allows them to pay off legislatures that might otherwise vote to enact strict rules. Tobacco companies have the money to ensure their continued success in exactly the same way they have done it for years, by playing dumb and paying off those who threaten to change the way they are required to do business.

Journal reference: *Journal of Chemical Research in Toxicology*; 2010.

Let's Find Out – Adding ammonia to the cigarette manufacturing process helps convert bound nicotine molecules into free ones. Once the cigarette is lit, the nicotine vaporizes into a gas, and then the moment inhaled, it is quickly absorbed by the lungs and distributed to the brain and heart, within 3 seconds. The short term effect is stimulation. The long term effect is depression. By smelling ammonia first hand, you will realize how this volatile toxin is robbing you of motivation, positivity, and confidence by poisoning your central nervous system.

Smoking a pack a day of AMMONIA-TREATED CIGARETTES is equivalent to smoking 700 cigarettes in 1960.



Which brand do you smoke? If it's a premium brand, you can bet that the nicotine has been treated to hook you. Researchers at *Oregon Health and Science University* used a laboratory smoking device to collect and analyze smoke from 11 brands of cigarettes. *The study measured the first three puffs of smoke* from each cigarette. In a court case between the state of ***Minnesota and the entire tobacco industry***, scientists at **RJ Reynolds** were trying to find out why their *Winston brand* was losing ground to *Philip Morris' Marlboro brand*, and in their research discovered that Marlboro contained ammonia compounds. Slowly but surely, **all the other premium brands** fell in line, and **started freebasing tobacco with ammonia**. "It was that juiced up nicotine that was putting ***Marlboro in a majority market share***, and everyone else out of business." (Marlboro settled the case for over **6 Billion in hush money**.)

According to highly cited chemist and researcher James Pankow, "Measurements ranged from about 1% all the way up to 35% FREE-BASE NICOTINE."

Dr. James Pankow: "The secret of Marlboro is Ammonia."

What You'll Need – One small container/sample of **common household ammonia**.

What To Do – Open the container of ammonia carefully now. **Slowly** bring your nose closer and closer to the top of the container until you catch a small sniff and smell the fumes. Even if you know what ammonia smells like, ***it is important to remind yourself now***, but be careful, the fumes can light up your nose like smelling salts.

Household Cleaning Chemicals and Products – You would NEVER taste ammonia because you have common sense and know the experience would send you to the hospital. But you are smoking it every day. Powerful cleansers are no joke! When cooked together in a cigarette, they become carcinogens for your body to deal with, ***stealing away your energy and your positivity***, one puff at a time. This chemical polluting of the system also contributes to elongated sicknesses, like head colds, flu's, viruses, and sinus and bronchial infections.

Nutrients your body needs – You must detoxify your central nervous system immediately. Vitamin B complex with niacin will increase your circulation for your entire circulatory system and detoxify your blood.

Part III. Pesticide

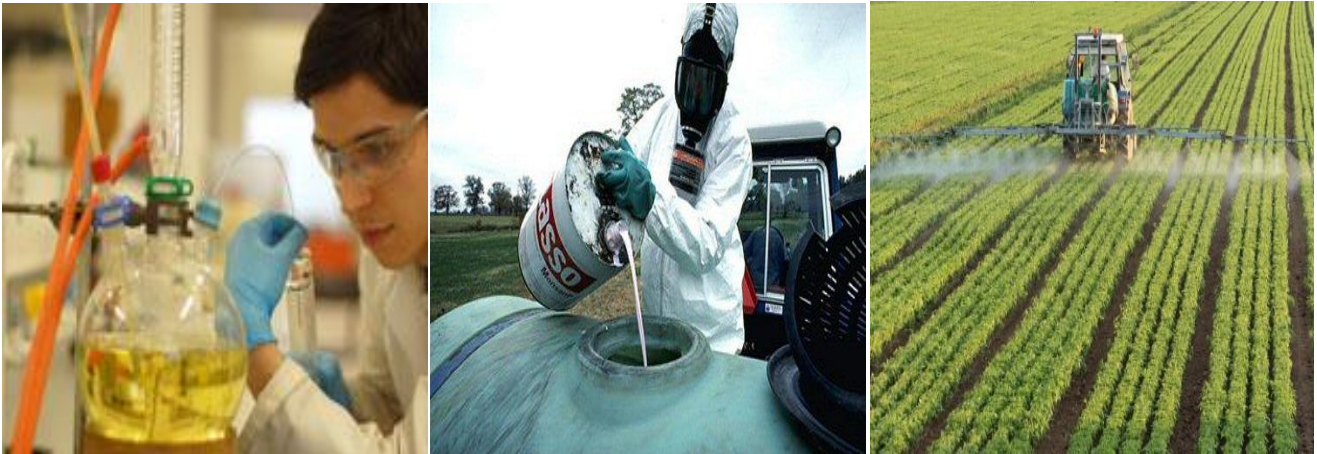

Face the Facts – The *compounds and poisons used for pesticides are lethal* and have lethal consequences in your system, that is why when you hear that **cigarettes have hundreds of chemicals** in them, you know it’s true. Ever heard of “**Roundup Ready Crops?**”^{*} Roundup comes from Dioxin, also known as “Agent Orange”, which gave many U.S. soldiers cancer in Vietnam. Now tobacco plant seeds are spliced with this poison to build tolerance of it.

Let’s Find Out – What is the difference between herbicides, insecticides, and pesticides? Now, we all know that they put pesticides on everything, not just tobacco. It’s on fruits and vegetables too; *so what’s the big deal with tobacco?* The Big Deal is that you are burning it and inhaling it. **Burning pesticides** is lethal. Pesticide is NOT the same thing as insecticide or herbicide. **Pesticides kill any life form which causes economic loss to vegetation**, like fish, mice, rabbits, turtles, and plants ... **and yes, humans. You are smoking pesticide.**

What You’ll Need – One small container/sample of **pesticide, insecticide or Roundup.**

What To Do – Open the container of *pest control substance* carefully now. **Slowly** bring your nose closer and closer to the top of the container until you catch a small sniff and smell the fumes. Even if you know what pest control substances smell like, *it is important to remind yourself now.*

Weed Killer, Bug Spray, Raid, RoundUp, Insecticide, Herbicide, Pesticide – How many ways can you spell poison? It’s bad enough it’s on the skin of fruit and vegetables, but it’s poured onto tobacco plants by the tons because these plants are bioengineered^{*} to withstand very large doses. **Unfortunately, humans are not.** Your body’s organs are being overwhelmed. Pancreatic cancer has the lowest survival rate of all cancers. **Don’t be a filter!**

Nutrients your body needs – Organic, all natural MULTI-VITAMINS are essential to your success in quitting and **remaining a non-smoker**. Check the resources and web links at the end of your Nutrition Guide for the best recommendations.

Part IV. Fiber Glass – Dissecting the habit

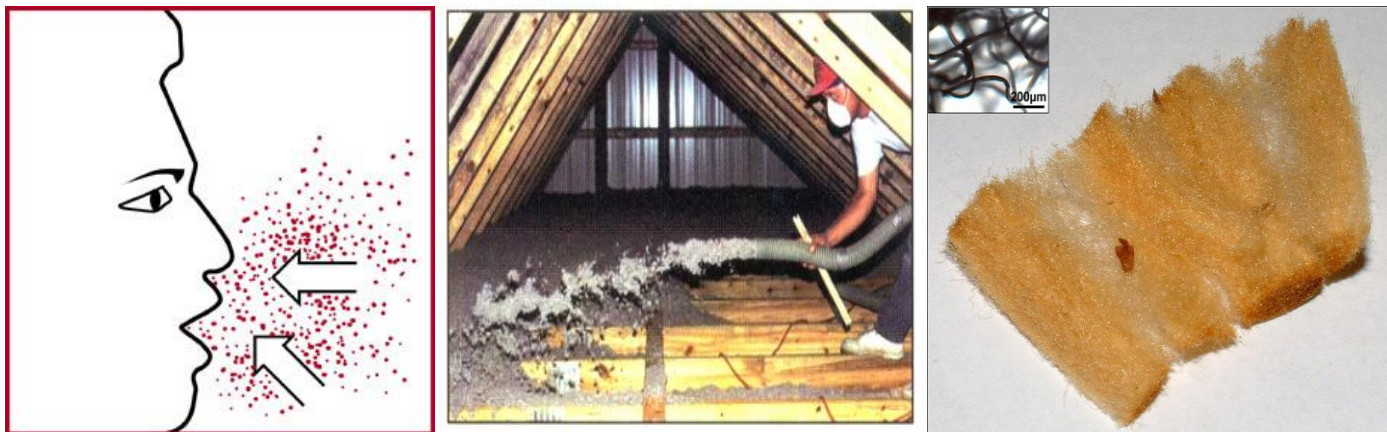

If a cigarette filter was simply made of cotton and paper, and you threw it out in the yard, it would break up and disintegrate after a couple of rainstorms.

Face the Facts – *Fiberglass became popular in the United States* in the early 1990's as Asbestos was phased out. Fiberglass is like asbestos in that it doesn't evaporate in the air, dissolve in water or react with most chemicals. **Tiny glass particles** are wrapped and bound tightly in the cigarette filters to **keep some of the tar** from entering your mouth, but many of these microscopic fibers **escape** into your mouth, throat and lungs.

The x-rays of lung cancer patients look like ground glass. Think now of why filters take up to 15 years to disintegrate. Also, fiberglass has the heat-resistant qualities that made asbestos so desirable for insulation. It acts as a buffer to heat. ***Now you know why your fingertips never even get warm, much less hot, when you smoke a cigarette all the way down to the filter.***

Let's Find Out – *If you have ever been in an attic and got insulation on your skin*, you already know those tiny fibers of glass from insulation wool can irritate your skin very badly, and also cause problems with your eyes. If you experience too much contact with fiberglass, it can cause what's called **irritant contact dermatitis**, or inflammation of the

skin. This happens inside the lungs of smokers, increasing the difficulty of breathing. Fiberglass is nothing more than **glass wool rolled** into bunches for insulating homes.



Straight from the dying rats in the cages to the grocers & convenient stores for \$5.

Make no mistake, fiberglass can be just as dangerous as asbestos -- and is sometimes referred to as the asbestos of the 21st century. A massive study in 1970 on rats stated that fibrous glass of small diameter is a potent carcinogen, leading to changes in the DNA genetic structure and breaking down the immune system. Politics and money prevent this from being popular knowledge now. Every drag you take on a cigarette you are inhaling glass fibers that cut up your lung tissue.

What You'll Need – Reach into your attic and pull out a small piece of insulation. If your attic is not easily accessible, you may also find it *around your hot water heater*. You don't need much, just about what three fingers can pinch off. Then, take out one cigarette, any brand will do.

What to Do - See for yourself! *Use scissors or a knife to cut the cigarette filter open*, and then tear it open. Hold it up next to your sample of fiberglass insulation. Can you see the glass fibers? If you have a **magnifying lens** around the house, you can see the fibers even better. This is also referred to as **GLASS WOOL**. Just think about the inside of your cheeks and the softness of the tissue. *That same soft tissue coats your throat and lungs.*

Nutrients your body needs – **Glass Wool** is making tiny tears in your lung tissue. This causes internal bleeding and vulnerability to cancer cells developing. Your body needs to repair itself, and it can! *You need to create a healthy environment for new cells* to develop that will beat down the bad cells. Vitamin B12 and Vitamin C are essential for this.

Also, avoid calcium supplements. Calcium actually protects parasites in your body. Instead, take magnesium to flush out the bad guys, and **look for mushroom complexes** at your local vitamin shop. This will build up your host immune system and fight off infection your lung tissue. *See the nutrition guide at the end of the course for details!*

Part V. Tar



A PACK-A-DAY SMOKER BREATHES IN UP TO A FULL CUP OF TAR IN A YEAR.

Face the Facts – Tar is the brown, tacky substance that stains a smoker’s teeth, fingers, throat, and lung tissue. Approximately ten to fifteen percent of tar makes it through the filter. Tar is present in all cigarettes and increases as the cigarette is burnt down, meaning the last puffs **may contain twice as much tar** as the first few. Tar paralyzes the cilia in the lungs, and causes emphysema, chronic bronchitis, and lung cancer. ***Tar also prevents your white blood cells*** from entering the lungs to consume pathogens and the impurities that cause infections.

Let’s Find Out – Think of how your **lung’s air sacks** are inhibited by the tar from fully expanding after they contract, making it harder to breathe. *Many smokers wake up coughing because their lungs try to take in more oxygen than when sleeping.* Glass particles and fibers **stuck in the tar** also make ***tiny tears in the tissue inside your body***, causing damage and susceptibility to infection, and eventually cancer. ***That’s why some lung cancer victims cough up blood*** near the final stages.

What You’ll Need – For this hands-on part, since you unfortunately can’t pull the tar out of your lungs, ***you can use something of similar consistency, like caulking, sealant, or even toothpaste.*** Go into your garage or shed and get a small sample, about a golfball size clump, or **squirt some toothpaste** onto a plate or in a bowl.

What To Do – Using your fingertips, ***mix your fiberglass insulation sample with the “tar”*** (toothpaste or caulking) sample, until you can’t separate the two. Try and rub off the tar with your other fingers. Can you? Try and blow on the goop like a cough. Is it coming off? Now think of this; if you can’t just **rub off** the goop with your fingers, you

certainly **can't cough it up** and out of your lungs. Picture this tacky tar coating your lungs. *No wonder nothing comes up when you cough!* Use warm water and soap to wash the fiberglass off your hands thoroughly.

Nutrients your body needs – Tar in the lung tissue can take some time to clear out, but the good news is you *can speed up that process!* On your next grocery trip, be sure to buy *fresh garlic, onions, spinach and ginger. Green tea is also a great antioxidant.* Also, cardio exercise is vital to helping your lungs expand and contract the way they should naturally. The increased blood flow will flush impurities out of your system faster.

Part VI. Cellulose Acetate & Photo Film



Why do cigarettes burn so hot (up to 1700 degrees), so evenly, and never go out in heavy wind? What's the trick?

Face the Facts - Cellulose acetate is a *synthetic plastic substance commonly used for photo film*. It burns very hot and efficiently. If cigarettes were rolled in simple paper, they would blow out in heavy winds. A smoker can drive down the highway at 55mph, hanging the cigarette out the window, *and it will not go out*. Also, a cigarette that is burning will not trail or “canoe” up one side. Once the ashes become uneven, they fall off, and even themselves out. This is because cigarette manufacturers carefully weave plastic particles into the matting of the stem to keep them burning evenly. This explains why cigarettes burn so hot, *up to 1700 degrees Fahrenheit during the drag. You're smoking plastic.*

The cigarette companies wouldn't want your **NICOTINE DELIVERY DEVICE** to go a couple times out before you get to the filter, *or you might decide it's a waste of money and quit!*

Let's Find Out - The "paper" stem is insulated and bound with wrapping mats of *acetate* (parts #24 and #18 in the following diagram). Notice below that part #28 is where the regular paper is inter-spliced, *keeping the cigarette from burning too quickly*.

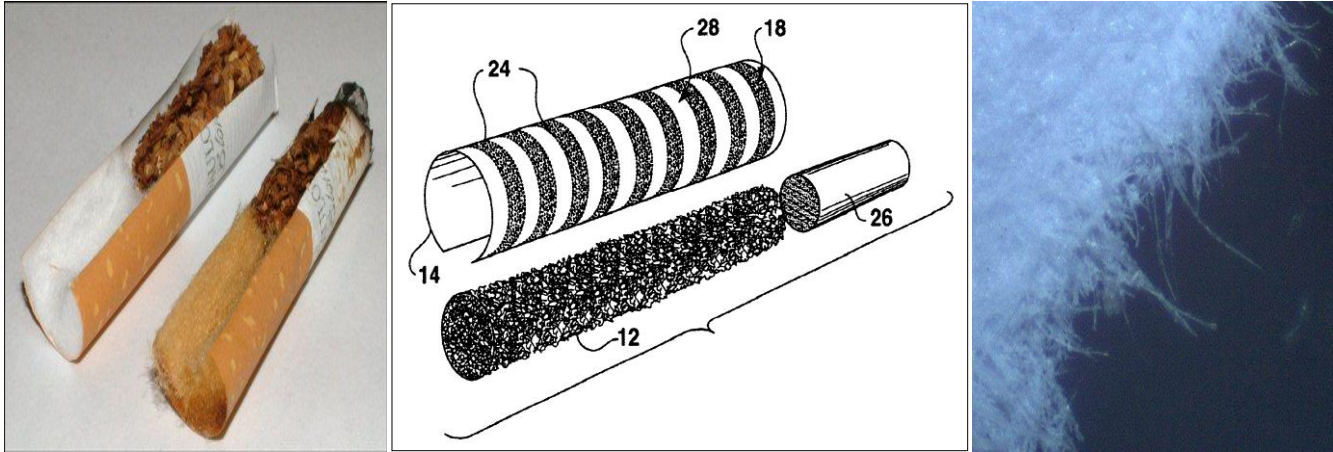

A cigarette is a highly engineered, efficient nicotine delivery device.

What You'll Need – One cigarette. You can use the same one that you used to examine the filter.

What To Do – *Seeing is believing!* Rip apart the STEM that holds all the tobacco. Clear the leaves away and make a tear in the paper. Look very closely *where you tore it*. Use a magnifying lens if you have one. You will notice that there are *fibers* protruding from the edge of the paper.

Nutrients your body needs – Cellulose Acetate is a form of plastic, so you are smoking plastic! *Why do you think breathing in second hand smoke is worse than actually smoking?* This synthetic substance combines with ammonia, bleach, and pesticide to create a lethal cocktail of poisons for your body. *You must detoxify.*

Check out advice on organic cleansers for your organs, especially your cleansing and excreting organs. Diatomaceous Earth is the best all natural product for killing parasites in your system. It's cheap too. You can simply mix it with juice and prevent cancer! Colon and prostate cancer are prominent forms of cancer that attack smokers. *You can rid yourself within days* of these poisons that are attacking your system and breaking down your immune system. See the **helpful websites** at the end of this course for more details.

Part VII. Organic Tobacco

*The key to weaning yourself off the cravings is to **cut out the chemicals that bring you down**. Eliminate ammonia, bleach, and pesticide, and you'll be able to feel the difference immediately!*



Face the Facts – Manufactured cigarettes contain ammonia, bleach, pesticides, glass fibers, plastic micro-crystals, **and much more in order to keep you hooked**, wasting your money and heading for the ultimate nightmare, chemotherapy.

Let's Find Out – How can you keep smoking for two more weeks and avoid all of the chemicals that bring you down – the very chemicals that are putting you in a frame of mind and body that craves to be uplifted? How can you **level off and balance your central nervous system**, so you aren't lacking the ability to naturally relax – so you won't ever experience the need for a "nic fix" again?

What You'll Need – You will need to go to a local tobacco or cigar shop and purchase some organic, additive free tobacco and some rolling papers (most tobacco packages come with papers). **Many health food stores** also sell organic tobacco. Check on line first and make a couple calls, so you don't drive all over town wasting gas and time.

What To Do – Try this kind of tobacco in order to ween yourself off of the high potency, ammonia treated nicotine brands and you may notice a difference right away. The goal here is to **limit yourself to three self-rolled cigarettes a day!** Remember, by rolling your own organic tobacco, you are avoiding the jacked up nicotine, lethal glass wool filters, plastics in the wrapping, and all the pesticides. **Detoxify yourself from the ammonia-treated nicotine**, and *then you can be done with cigarettes forever.*

Part VIII. Do The Math!

You may have already figured this out, but now that you're really going to quit, do it again just for fun!

One cigarette pack = \$4.00+ (on average)

A pack a day = \$125.00 per month as a minimum ...

12 months = 1 year = \$1500.00

A couple that smokes spends \$3000+ a year. Plus you waste money on lighters, gas, health care costs, dry cleaning, dentistry, doctor's bills, life insurance premiums, and much more.

For \$3,000, you could book a ***vacation for two***, including air fare and hotel, to **Acapulco, Hawaii or Costa Rica** for ONE FULL WEEK every year.



**OR ... YOU COULD GET A FULL-BODY MASSAGE EVERY WEEK,
WHICH RELEASES TOXINS!**

Part IX. The Pills, the Patch, and Nic-Gum.

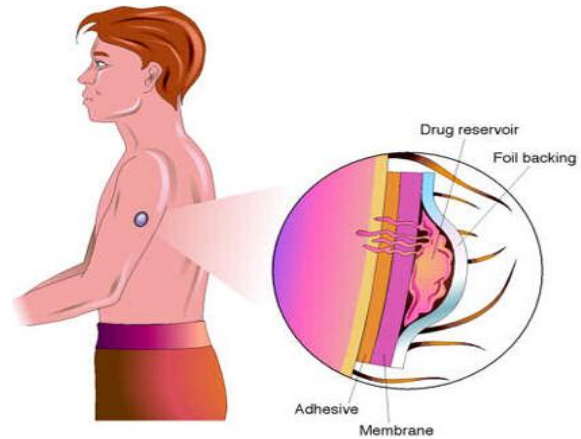

Quitting cigarettes is physiological, emotional, and it's mental. Most cessation programs address one and only one thing – the nicotine, *and they're not even doing that right!* ***This course is comprehensive.*** We are covering breathing patterns, your central nervous system, confidence, relaxation and WHAT CIGARETTE MANUFACTURERS DO to keep you hooked. **WHO do you think** is SELLING YOU the pills, patch and gum? Even if any of these options get you to quit, most smokers go back later when something stressful happens because these are only *temporary fixes and the companies that market them know it.*

Question: Why do the pills, patch and nicotine gum fail?

First, let's start by understanding the DOSE OF NICOTINE YOU'RE REALLY GETTING:

ONE CIGARETTE delivers up to 100 milligrams of nicotine potency.

NICOTINE GUM delivers between 2 and 4 milligram per piece.

NICOTINE PATCH delivers less than 1 mg (between .5 and .9 mg) each hour.

THE PILLS don't contain nicotine at all but block the brain's receptors to it, which is very dangerous and creates side effects, including suicidal thoughts. Just read the side effects of meds like *Chantix and Zyban* for the whole horror story.

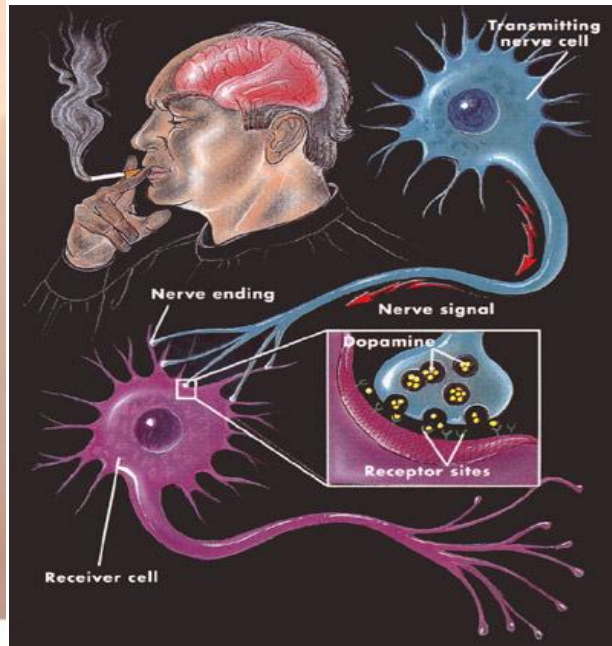

Why are Drugs like Chantix and Zyban so dangerous?

THERE'S A WAR going on inside your body and brain right now: Nicotine versus Dopamine. Are you tipping the scales **more and more everyday** away from your favor? Which one will win? Let's talk about how your body deals with stress naturally.

Your body creates Dopamine to help you with stress, anxiety, confidence, relaxation and energy, depending on the situation and how your **Central Nervous System interprets** the need for it. By over using Nicotine year after year, eventually your body will stop creating Dopamine, and **rely on Cigarette's 100%, the same way Diabetics have to take insulin shots periodically throughout the day.**

In the diagram, you can see how drugs used to quit smoking, while blocking the nicotine receptors in your brain, can **also block the Dopamine** by creating a wall near the nerve endings, **ruining your natural "fight or flight" reactions**, which makes all of your little problems seem insurmountable, which in turn leads to feelings of anxiety and even suicide. You are getting "false confidence" using nicotine. **It's physical and it's mental.**

Stimulants Produce Short-lived Euphoria:

Danger: With repeated use, stimulants can **disrupt the functioning of the brain's dopamine system, dampening users' ability to feel any pleasure at all.** Users may try to compensate by **taking more and more** of the drug to experience the same pleasure.

Part X. The Art of Breathing ...



Hold your fingers now as if you have a cigarette and inhale, hold for one to two seconds, and then exhale. Breathe so you can hear yourself. Now do that for as long as your cigarette would last. **Notice your breathing technique is QUITE DIFFERENT than when you are not smoking.** *Understand this is one of the main reasons why cigarettes relax you and make you feel better.* This is half the battle of quitting right here. If you can *breathe this way every time you crave a cigarette* for three days, it's over.

Three days after you stop smoking, your natural dopamine levels will return, and your body can react like it used to, **before you were a smoker**, and you will have all of those moments you have as a smoker, without ever touching another cancer stick.

Have no doubt about it, **chemicals fuel panic attacks**, anxiety, nervous disorders, sleeplessness, and depression. Many smokers wake up in the morning coughing, which begins the day with stress. Other smokers quit the habit, **only to go back when stress hits**, in need of that little rush of “ambition” or that “feeling of relief” from stress, when in actuality, that feeling can be tapped into naturally.

Practicing breathing patterns **while you are not stressed** prepares you for stressful situations. Then, by drinking spring water, eating organic chocolate, and taking vitamins and supplements, your body is ready to **release dopamine, serotonin, adrenalin**, and much more as you call upon it with your reactions to your environment.

Relaxation Tip: Notice the moments between breaths, when you are not inhaling nor exhaling. ***This relaxes your central nervous system!*** Take “fake” smoke breaks at work and practice breathing the same way. After meals, **this kind of breathing aids in digestion**. Upon waking up, you should guide yourself gradually from breathing at 75% to 100%.

What is clear is that the modern cigarette is a highly engineered nicotine delivery device. It's not just the smoke that's killing you, **it's the chemicals**.

Answers to the Cigarette Test

Do not read until you have attempted written answers to each question.

1. **Five common household products** used to make cigarettes are: Ammonia, Bleach, Pesticide, Fiberglass and Cellulose Acetate (Photo Film Plastic).
2. Cigarettes are rolled in paper, which comes from trees, which are brown. The paper is bleached to give it that “clean” look. **You’re smoking bleach.**
3. You are addicted to **nicotine** *at some level*. Nicotine is ***the third most powerful major drug addiction***, closely behind cocaine and heroin. Most cigarette manufacturers use **Ammonia to turn nicotine into a vapor ready form** by converting bound molecules into free molecules; this makes the nicotine up to 35 times as potent. You’re getting up to **100mg of potency** in one cigarette.
4. *Corporations like Monsanto* **bio-engineer tobacco seeds with weed-killer** called **RoundUp** so farmers can spray **unlimited amounts of this poison** on the tobacco plants without harming them. Now ***tobacco contains more pesticide, more herbicide, and more insecticide than ever before.***
5. In addition to **hundreds of chemical pollutants**, filters contain **glass wool fibers** that prevent them from evaporating or disintegrating for up to 15 years. **Tiny micro-crystals of glass** block *some of the tar* and **keep the filter cool** so your fingers don’t get hot when you smoke the cigarette -down to the nub, but **some of the glass fibers escape into your mouth, throat and lungs**, leading to tiny lung tissue tears which lead to cancer.
6. Wrapping mats of cellulose acetate, **a common plastic substance found in photo film**, burn at up to **1700 degrees Fahrenheit**, keeping cigarettes from going out in heavy winds. The cross matting design keeps them burning evenly. *You’re smoking plastic.*
7. **A mostly acid system in humans**, instead of a mostly alkaline system, **is less energetic and more prone to infection, disease, and chronic ailments.** Cigarette smoke, alcohol, meats, dairy products, salts, sugars, pharmaceuticals, gluten and artificial sweeteners are typical acid producers. Fast food and diet soda drinks are the most common contributors.
8. The patch and gum are nothing like smoking, only delivering between 1 and 3 milligrams of nicotine per hour, where cigarettes deliver up to 100 milligrams of **potent nicotine.** The pills do not contain any nicotine, but block the brain’s receptors to it, **and also block naturally occurring dopamine and serotonin**, causing anxiety, insomnia, depression, **feelings of suicide, and sometimes suicide.**

9. No agencies currently regulate the potency of nicotine. There are no legal regulations.
10. A different breathing pattern, meditation time, a quick feeling of relaxation, “back to normal feeling,” a confidence boost, a change of environment (fresh air), after meals, helps breathing upon waking up (like menthol), a supplement to alcohol are all feelings, habits and/or rituals to which smokers may be addicted.
11. Most people’s *breathing pattern is better* when smoking, since they take long inhales, hold for a second or two, and then long exhale. This is similar to yoga breathing practitioners, and **those who meditate**, except they inhale through the nose, exhale through the mouth.
12. Sipping a 32 ounce soda throughout the day, munching on trail mix, eating candy and suckers, smoking cigarettes, biting your nails, or sipping beers *all night* are hand to mouth habits. If you smoke a pack a day, you experience up to 250 hand to mouth motions, and two packs a day up to 500 hand to mouth motions.
13. Most smokers leave their immediate environment to smoke, *whether at work, home, restaurants, and now most bars*. This usually means you’re *escaping the hustle and bustle*, and providing yourself with time to think and reflect – a form of meditation.
14. **Breathing deep and properly** aids in digestion, so, since smokers are engaging in their “breathing ritual,” they are aiding digestion, even though they are polluting their system with chemicals. That is why the after-meal cigarette is so common.
15. **Organic, additive free tobacco** is sold in most tobacco and cigar shops, and on line.
16. The art of breathing involves **long inhales through the nose**, holding in for a second or two, **and a long slow exhale out of the mouth**. Focusing on the moments between breaths *calms the nervous system* and is the *best medicine for relaxation and meditation*.
17. **Nicotine is a stimulant in the short term so it suppresses appetite**. When people quit smoking and do not take vitamins and supplements, they often battle depression, which is **fuel for aggressive eating**. Fresh, raw vegetables and nuts and seeds are **the keys** to getting proper protein and nutrients and not putting on weight. Avoid all artificial sweeteners common in “diet foods and diet drinks.” *They actually increase appetite*.
18. *You can now despise the cigarette manufacturers for tricking you into wasting your time, money, and energy*. **You will be a non-smoker for life. Attitude is everything!**
19. Smokers who quit can **kill the urge** to smoke by practicing breathing during times they would have been smoking, and by using **vitamins, supplements and nutrition** to replace

and *replenish levels of dopamine and serotonin, and balance their central nervous system.*

- 20.** Pills like Chantix and Zyban not only block the brain’s nicotine receptors, but also **block the body’s naturally created dopamine and serotonin**, creating **more anxiety** and even feelings of suicide. Suicide is actually listed as a side effect of these medications.

Section II. Nutrition & Mindset

So many smokers worry about putting on weight and getting anxious, cranky, or depressed after quitting.

I know why it happens, and I have the cure for you. Nicotine is a stimulant in the short run, but in the long term it’s a depressant, driving you down, taking away ambition, motivation, and confidence. Don’t let these “thieves” steal your natural will and relaxation from you.

Do you know about naturally occurring Dopamine and Serotonin?

This section of the course is a quick, comprehensive review of nutrition from top nutritionists all over the world! This section covers how to replace nicotine with natural supplements and replenish your system so you never ever crave another cigarette, and you never go back to smoking again.



Nutrition & Mindset Pretest

*Let's see how much you know about **which nutrients are depleted in your body, and what plan of action is best for staying away from cigarettes forever.***

1. **SPRING WATER** has exactly what the body needs to balance your system. Spring water is vitally important to drink when you stop smoking cigarettes. *What major function is lacking in your body due to the chemicals in cigarettes?*
2. **DARK, ORGANIC CHOCOLATE** is different than the cheap stuff you get in snickers or peanut butter cups. *What mental condition or state of mind does chocolate help correct as a natural way to replace nicotine's function?*
3. **WHICH VITAMIN** will help balance your central nervous system, *and give your body niacin, which is severely depleted due to smoking? (This vitamin is sold as a complex and should be organic! Do not buy Centrum or Equate.*
4. **WHICH AMINO ACID** combines to help you fight depression, cure anxiety and chronic fatigue?
5. **WHAT NATURAL CHEMICAL IN YOUR BODY** helps you in crisis situations and also gives you "fuel" for confidence and sex drive?
6. **WHAT VEGETABLE** is sold as a natural supplement that millions of asians take to build up a host of immunity to protect their bodies from viruses, diseases, and infections. Hint: you can't eat the ones that grow from the ground in your yard?
7. **WHY ARE SUGAR SUBSTITUTES SO BAD FOR YOU?** Aspartame, Sucralose, Saccharine and Sorbitol are the ingredients in Equal, Splenda, Sweet-n-low, and Spoonful. *What opposite effect do they have than the general public thinks?*
8. **WHY ARE RAW VEGETABLES** the cure for cancer? What vitamins and proteins can you get from uncooked veggies that you cannot get from bread, milk, and meat?
9. **MECUNA** is a natural supplement which increases your **DOPAMINE DEFICIENCY** that you have from smoking chemically treated nicotine. What happens when you don't have enough dopamine and something stressful happens?

10. QUITTING SMOKING IS PHYSICAL, EMOTIONAL AND MENTAL. After you quit physically and you supplement your heart and central nervous system with proper vitamins and nutrients, you have to address the mental aspect. *What form of “coaching” is best for this mental de-activation of the cravings of a cigarette?*



Glossary:

- 1. Measurable Potency:** Ammonia treated nicotine potency does not register on nicotine level testing, so the true dose of nicotine in premium brands can reach 100 mg. per cigarette.
- 2. Nicotine:** A drug which acts as a stimulant in small doses, but in larger amounts blocks the action of autonomic nerve and skeletal muscle cells.
- 3. Nicotine cycle:** The nicotine addiction is broken in 3 to 4 days physically, but the mental and emotional need for the drug remains for up to two weeks.
- 4. Potential:** The maximum ability of nicotine to depress physical and mental functioning by replacing natural body chemistry.
- 5. Total number of smokers in U.S:** An estimated 25 million men and 21 million women smoke cigarettes currently in United States of America.
- 6. Round Up:** The largest brand name for pesticide and herbicide in the world; contains dioxin which is a known toxin proven to cause cancer in animals and humans.
- 7. Righteous Hatred:** It's ethically and morally ok to hate something that tries to bring you harm. Cigarette manufacturers have gone out of their way to hook you and keep you.

Answers to Nutrition Test:

1. Spring water ensures healthy cell production
2. Chocolate fights depression.
3. Vitamin b complex with niacin.
4. The amino acid L-tyrosine. Ask about branch chain aminos also.
5. Dopamine helps you deal with crisis and stress naturally.
6. Mushrooms! Check out reishi, cordyceps and maitake as part of a mushroom complex.
7. Sugar substitutes are synthetic and trick your body into craving more food and sugar.
8. Raw vegetables have all the nutrients humans need. By fueling your healthy cells with veggies, you fight cancer and win!
9. Lack of dopamine leads to anxiety, panic attacks, and worst of all – lighting up a cigarette. Go get your supplement of mecuna! (also called dopabean)
10. Hypnotherapy is the best way to keep from going back to smoking. Plus it's harmless. Keep an open mind and you will be a non-smoker forever!

Google helpful information and other important links for Vitamins, Supplements and Hypnotherapy:

Dr. Lorraine Day ☆

Medicinal Mushrooms ☆

Findaspring.com (find spring water from the ground and bottle it!)

Matrixtransformation.com ☆

SacredChocolate.com ☆ David Wolfe

Guraw.com ☆

PuritansPride.com ☆

TheVitaminShoppe.com

Blessedherbs.com – colon cleansers ☆

www.drnatura.com/Colon-Cleanse

www.herbdoc.com/kidney cleanse

**Remember, all supplements are not for everyone. Consult your Naturopath or Nutritional Specialist and do more research on line.*

You can do it! Your shoppers guide is next. Print it and laminate it at Office Max or Office Depot, and then put it in your purse or wallet. Take it with you to the local vitamin and supplement store and to the grocery store. Try to buy only organic food, drinks and vitamins!

THE NONSMOKER'S

SHOPPER'S GUIDE!

YOU NOW HAVE THE KNOWLEDGE, THE DRIVE AND THE ABILITY TO ALWAYS REMAIN A NON-SMOKER.



Spring water: Balances system and aids in healthy cell production/DNA.

Dark chocolate/organic: great substitute for nicotine when dealing with depression.

B-Complex Vitamins: for balancing your Central Nervous System, especially with **Niacin**.

L-Tyrosine: An Amino Acid; fights depression, cures anxiety and chronic fatigue!

Mecuna: great for Dopamine deficiency. Also works as antioxidant and quells appetite!

Medicinal mushrooms: Build your immunity up against colds, flu's, viruses and bacteria! (ask for mushroom complex)

****Also – Milk thistle detoxifies your liver of the pesticides!!**

Use Garlic, Honey, Cinnamon, and Olive Oil in your favorite dishes.

No Synthetic Sugars! No Aspartame! No Sucralose! No Sorbitol! No Splenda! No Equal!

Lots of fresh vegetables - wash them off! (Cabbage is fuel for Serotonin/Dopamine!)

My research originates from:

Johns Hopkins University, USA

Oregon Health & Science University, USA

Bath University, UK

Ontario Institute for Cancer Research, Canada

*The majority of this research is synthesized from Medical Universities in Canada and in the United Kingdom, where they have Universal Healthcare, and the Government pays to try and heal the sick and dying. **In the United States,** fortunes are made by pharmaceutical companies that treat the sick and dying with chemotherapy and expensive prescription drugs in order to suppress the symptoms, yet rarely cure the problem.*



Above: Dr. James Pankow

“The prevention and cure for cancer is in your hands.”

S.D. Wells.

Congratulations!

IMAGINE THIS:

You've quit smoking, and you're spending \$150 less per month. Your clothes don't smell like smoke, your breath is fresh and you've been working out and feel great. Then stress comes. Some situation arises and some friend standing next to you lights up a cigarette ...

And so you stare at it for a second, and then you laugh a little to yourself and then smiling at your friend, you put up your first two fingers, and pretend to take a drag. Then you take a deep breath and grab a water bottle, knowing you're a non-smoker who is never going back. It's all mental from there.

